

# INSTALLATION INSTRUCTIONS

0996/091/00

Issue 01

## BRITON 996 FIG.1

### ELECTRO MAGNETIC HOLD OPEN/FREE SWING DOOR CLOSER 24VDC

#### SURFACE FIXED TO 'PULL' (HINGE) SIDE OF DOOR.

**SIZE 3** closer suitable for doors up to 950mm wide and 60kg in weight

**SIZE 4** closer suitable for doors up to 1100mm wide and 80kg in weight

**SIZE 5** closer suitable for doors up to 1250mm wide and 100kg in weight

This closer unit incorporates an electro magnet which is normally interfaced with a detector/alarm system. In an emergency or a power failure, the electro magnet when de-energised will cause the closer to close the door into its frame. A 13mm A/F spanner is required to carry out adjustments to arm set or convert from hold open to free swing function.

Hold open function enables unit to hold door open until automatically released or pulled closed manually. Angle of hold can be adjusted from 85° to 95° approx. and 103° to 110° approx.

Free Swing function setting allows door to be independent of closer control. When unit is automatically released the door will be driven closed from whatever position it may have been left open. Adjustment of catch plate provides for a free swing variance of 85° to 95° approx. Door can open to approx. 110° max. subject to hinge projection and surrounding structure.

**Warning:** When Briton 996 is used in the free swing mode the door is not under the control of the damping action and will slam in windy or draughty conditions.

THIS CLOSER UNIT IS EASILY CONVERTED TO SUIT EITHER HAND OF DOOR, for conversion instructions see diagram 4.

#### IMPORTANT

Door must swing freely and close firm into its rebate to enable the closer to operate efficiently. This is particularly important for fire/smoke doors and we recommend that doors be hung on ball bearing butt hinges to BS EN 1935 and that latches and smoke seals be of a type that offer minimum resistance to closing. Failure to address these requirements may result in an ineffective fire/smoke door installation.

DOOR STOP MUST BE FITTED TO PREVENT DOOR FROM OPENING JUST BEYOND SET ANGLE OF HOLD OPEN OR FREE SWING SETTING.

Under no circumstances should the door closer be dismantled.

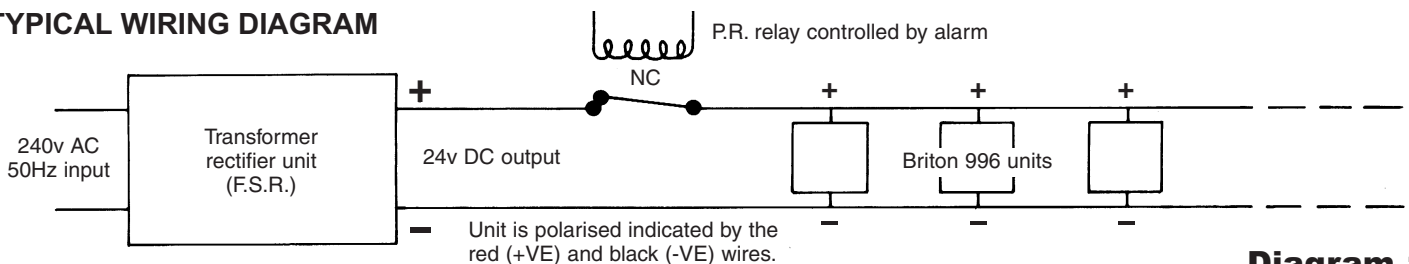
## ELECTRICAL INFORMATION

**SPECIFICATION** Electro-magnet continuous rating: 2.35 watts max at 26v DC.  
Power Requirements: 24v DC - 90 mA nominal.

**TESTING** Check that voltage is within specified range at each unit after installation.  
It is recommended that the equipment is tested at weekly intervals for correct function.

**NOTE:** Power for ancillary devices must not be drawn from the alarm system except under alarm conditions and then must not reduce the reliability of the supply. (BS.5839 Pt. 1).

#### TYPICAL WIRING DIAGRAM



**NOTE:** Power supply feed to electro magnet is through flexible armoured loop.

#### IMPORTANT

This closer should be installed by a competent fixer who must pass these instructions onto the site or maintenance manager once the closer unit has been satisfactorily fixed, wired and tested.

**No Responsibility** can be accepted by the manufacturers if these installation instructions are disregarded.

# APPLICATION

Briton 996 unit fixed to top rail of door.  
Arm bracket fixed to head frame.

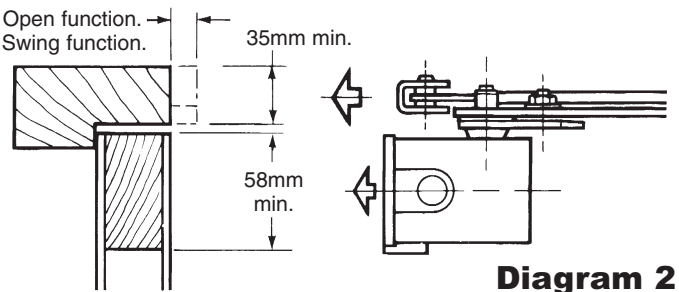
## See Diagram 2

### \*Note:

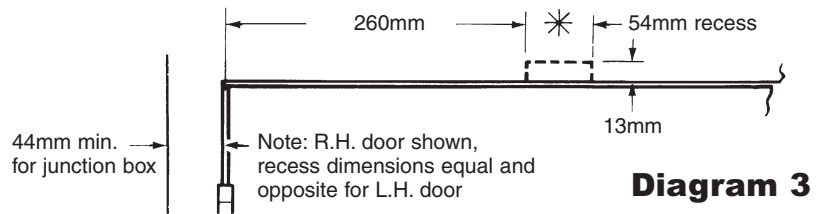
Head frame will need to be recessed locally to clear claw and catch plate on unit if head frame projects from door face.

## See Diagram 3

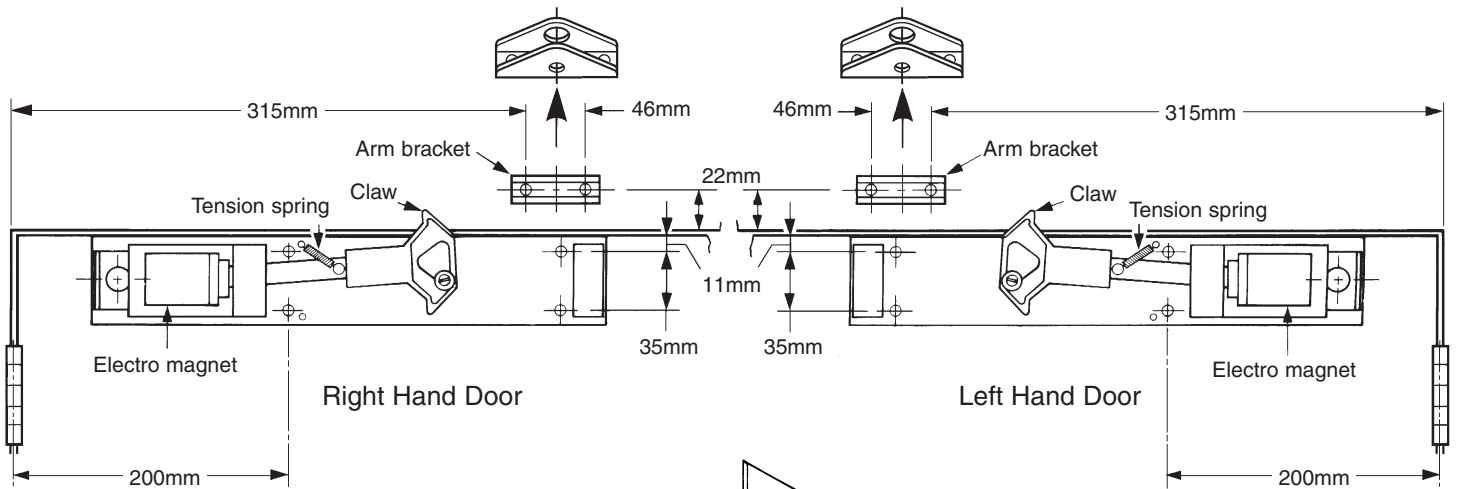
30mm max. head projection for Hold Open function.  
20mm max. head projection for Free Swing function.



**Diagram 2**

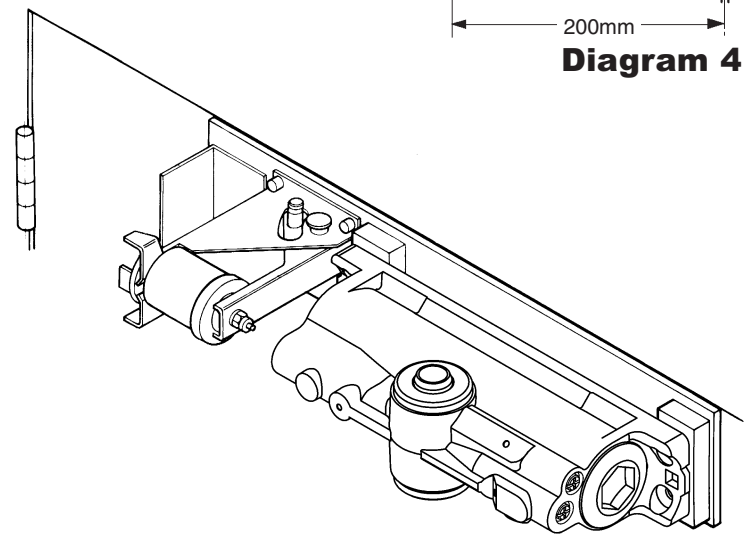


**Diagram 3**

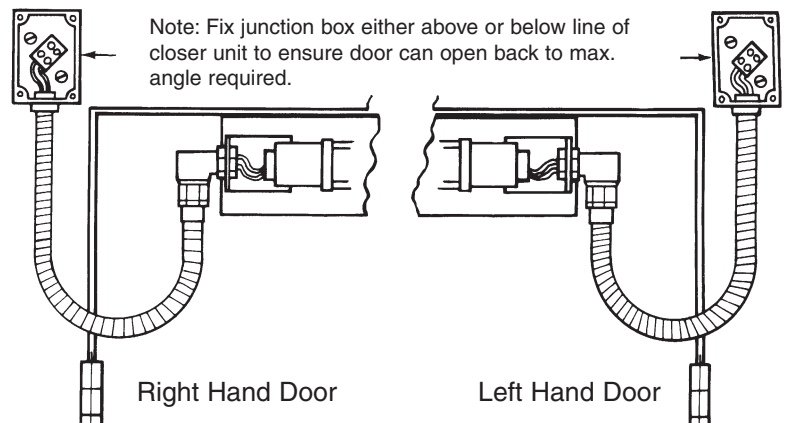


**Diagram 4**

- 1) Remove closer from backplate.
- 2) Securely fix back plate **level** with top edge of door ensuring electro magnet is **nearest** hinge for either hand of door.  
**See Diagram 4**
- 3) Attach free end of tension spring to upper peg ensuring end locates into groove.  
**See Diagram 4**  
Depress claw and check for free return.
- 4) Securely fix arm bracket assembly to head frame.  
**See Diagram 4**
- 5) Re-fix closer securely to backplate ensuring hexagon recessed end of closer is **furthest** from hinges.  
**See Diagram 5**
- 6) Fix junction box complete with box plug and armoured loop to door jamb. Attach elbow end to angle bracket on back plate. Connect wiring to electro magnet terminals.  
**See Diagram 6**
- 7) Complete wiring installation, refer to diagram 1. Refix cover plate to junction box.
- 8) DETERMINE WHETHER UNIT IS TO HOLD DOOR OPEN OR ALLOW IT TO 'FREE SWING' AND AT WHAT ANGLE FOR EITHER FUNCTION, THEN PROCEED AS FOLLOWING PAGE.



**Diagram 5**



**Diagram 6**

# SETTING ARM SET FOR HOLD OPEN

Couple main arm of arm set to catch plate by inserting bolt centrally within middle slot.

**See Diagram 9**

## 85° to 95° RANGE OF HOLD OPEN

- 1a) Insert arm set spindle into top of closer at 90° to backplate and secure with arm retaining screw.

**See Diagram 7**

Proceed as paragraph 2 below.

OR

## 103° to 110° RANGE OF HOLD OPEN

- 1b) Insert arm set spindle into top of closer with arm **towards** hinge and 60° to back plate. (Check for correct angle using template on back page.) Secure Spindle with arm retaining screw.

**See Diagram 8**

Remove catch plate nut, bolt and washers and swing arm away from hinge until bolt can be re-inserted in end slot.

**See Diagrams 9 and 10**

Proceed as paragraph 2 below.

- 2) Untighten nut, pull main arm **towards** hinge until bolt is restricted and tighten nut. (THIS WILL GIVE MINIMUM HOLD OPEN POSITION).

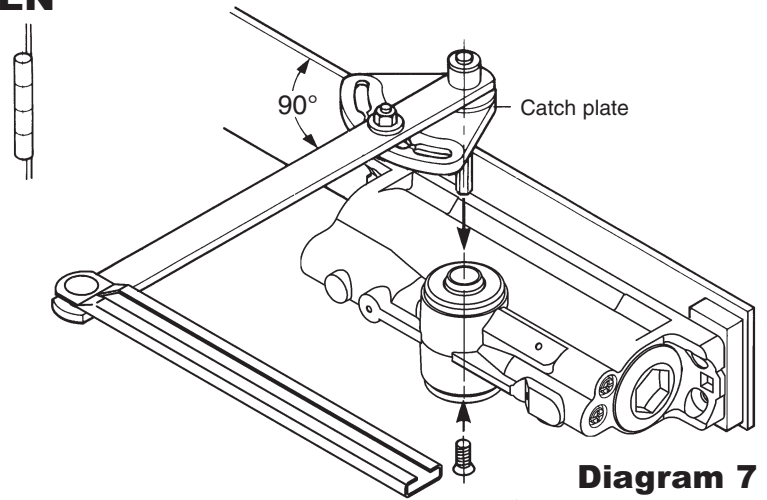
- 3) Open door to engage secondary arm strip and tube. Close door and set secondary arm at 90° to door face. Securely tighten arm clamp bolt.

**See Diagram 11**

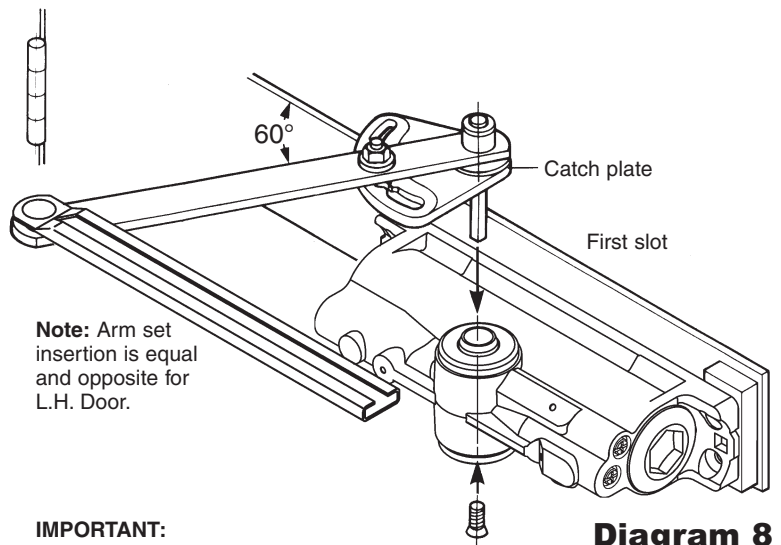
4. Switch power on to energise unit magnet and open door until hold open is achieved.

5. Slacken nut and move door to required hold open angle, then **securely** re-tighten nut.

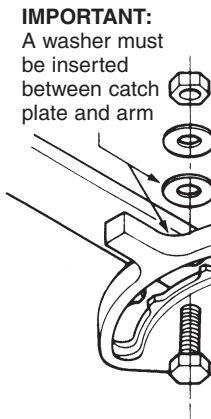
6. Check that door will be released from this angle by de-energising the unit magnet.



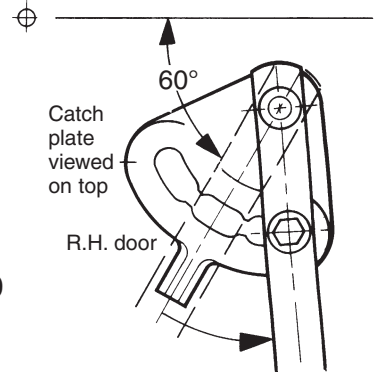
**Diagram 7**



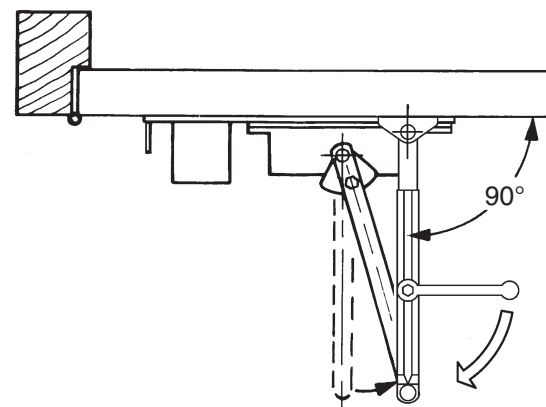
**Diagram 8**



**Diagram 9**



**Diagram 10**



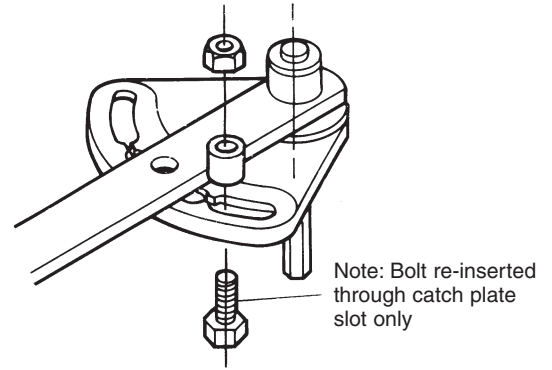
**Diagram 11**

# SETTING ARM SET FOR FREE SWING

(85° to 95° VARIANCE)

1c) Insert arm set spindle into top of closer at 90° as paragraph 1a.

2c) Remove catch plate nut, bolt and washers. Discard both washers and re-insert bolt into elongated slot **furthest** away from hinge. Place spacer over bolt and retain with nut. Pull main arm **towards** hinge and lock spacer down in the 85° position.

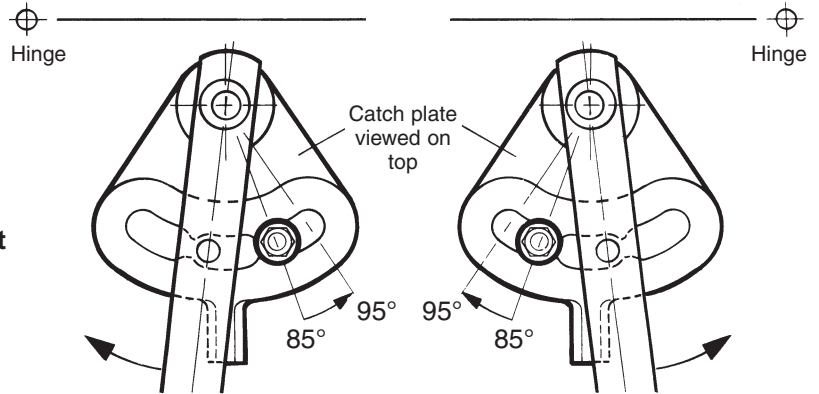


**Diagram 12**

**See Diagrams 12 and 13**

3c) Assemble secondary arm and set length, connecting arm to arm bracket all as para. 3.

4c) Open door until catch plate engages claw and door free swings. **To increase free swing angle**, slacken nut, hold door at required free swing angle. **Ensure spacer is bearing against side of arm** before securely re-tightening nut.



**Diagram 13**

5c) De-energise unit magnet and check that claw releases catch plate causing door to close into its frame rebate.

## ADJUSTMENT TO CLOSER

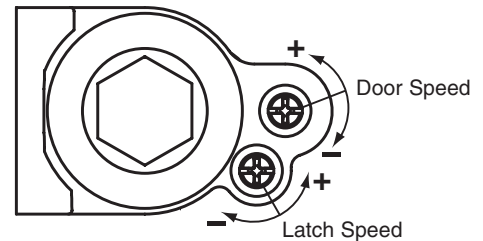
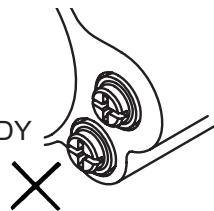
### Closing speed and Latch Action Adjustment.

Turn regulator for suitable closing speed  
+ faster or – slower.

Turn regulator for suitable latch speed  
+ faster or – slower.

**See Diagram 14**

**WARNING: REGULATORS MUST NOT BE UNSCREWED BEYOND SURFACE OF BODY**



**Diagram 14**

### TESTING UNIT

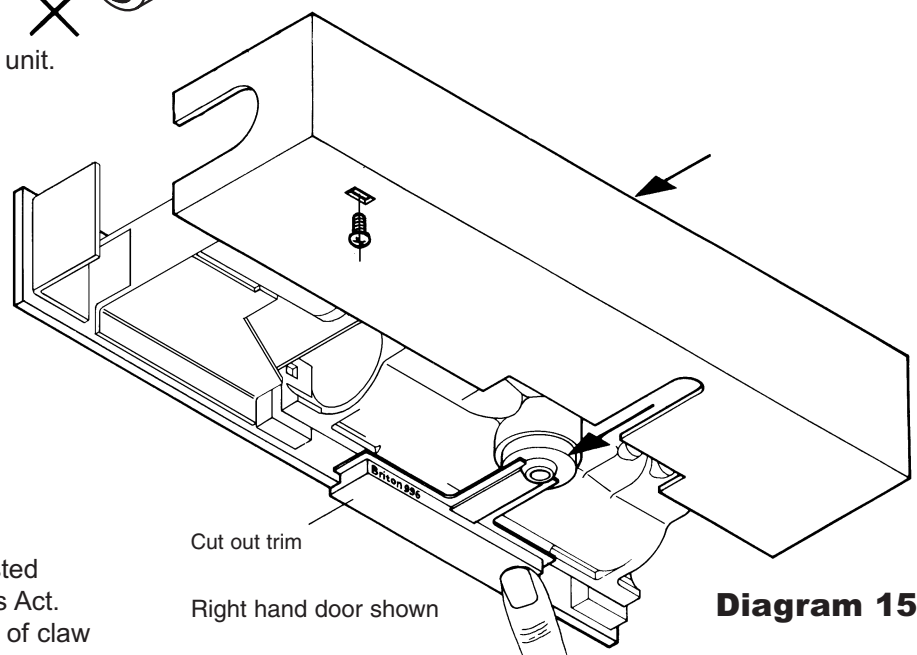
Switch on power supply to apply 24vDC to unit. Open door until either hold open or free swing function has been achieved. Switch off power to de-energise unit and observe that closer returns door, under check control, firmly into frame.

Hold cut out trim in position behind lower spindle boss of closer butting up against back plate of door. Slide cover over unit ensuring trim is retained. Finally secure cover with two small screws.

**See Diagram 15**

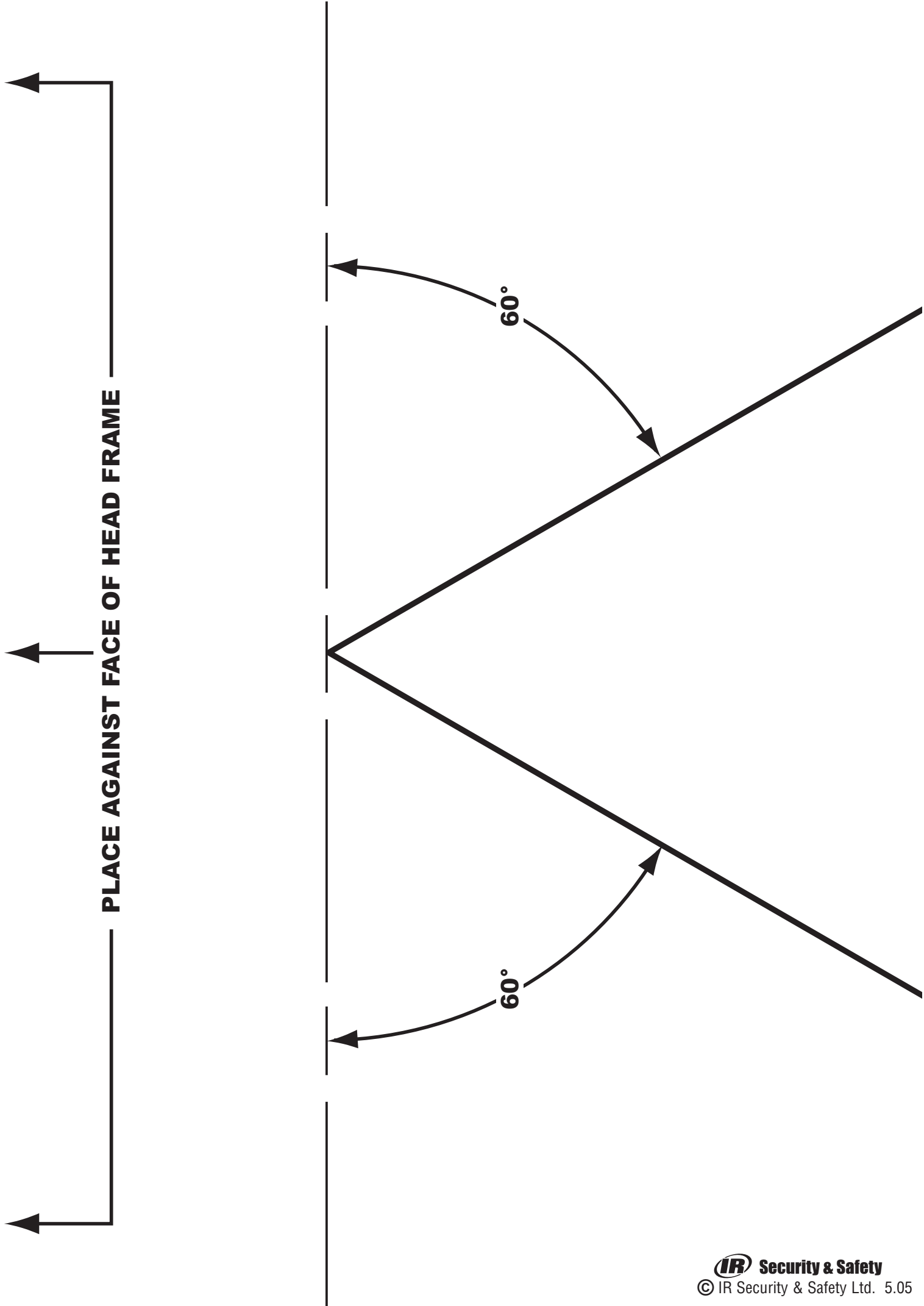
### MAINTENANCE

Keep free from dust and dirt. Unit to be tested weekly in accordance with Fire Precautions Act. Periodically apply grease to projecting part of claw and a small quantity of oil to arm joints and door hinges.



**Diagram 15**

**PLACE AGAINST FACE OF HEAD FRAME**



# SUPPLEMENTARY INSTALLATION INSTRUCTIONS

0996/092/00

Issue 02

## BRITON 996 FIG.61

## ELECTRO MAGNETIC HOLD OPEN/FREE SWING DOOR CLOSER

### TRANSOM FIXED TO 'PUSH' SIDE OF DOOR AND FRAME

**SIZE 3** closer suitable for doors up to 950mm wide and 60kg in weight

**SIZE 4** closer suitable for doors up to 1100mm wide and 80kg in weight

**SIZE 5** closer suitable for doors up to 1250mm wide and 100kg in weight

For **GENERAL NOTES** and **ELECTRICAL INFORMATION** refer to main instruction sheet.

**NOTE:** The armoured cable with junction box, supplied with this closer, is not intended to be used for this application but may be used as an alternative means of carrying the wiring to the electro magnet.

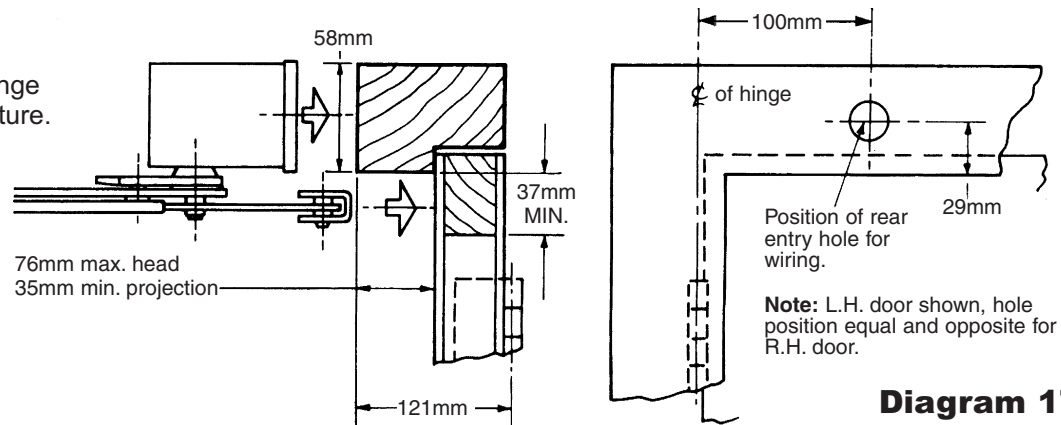
### APPLICATION

Max opening 95° subject to hinge projection & surrounding structure.

Briton 996 unit fixed to head frame.

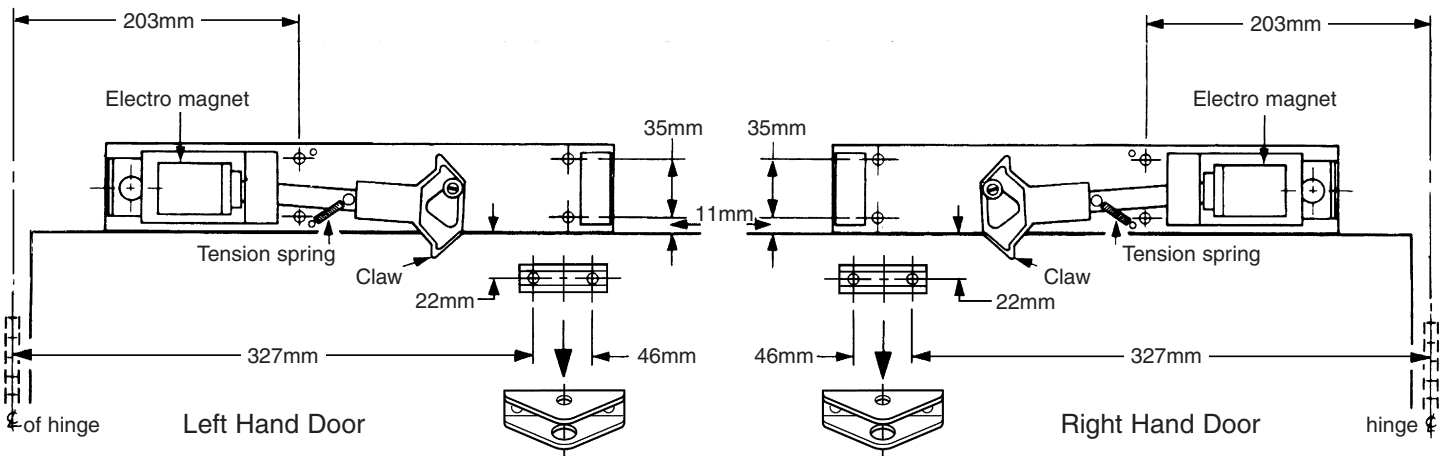
Arm bracket fixed to top rail of door.

See **Diagram 17**



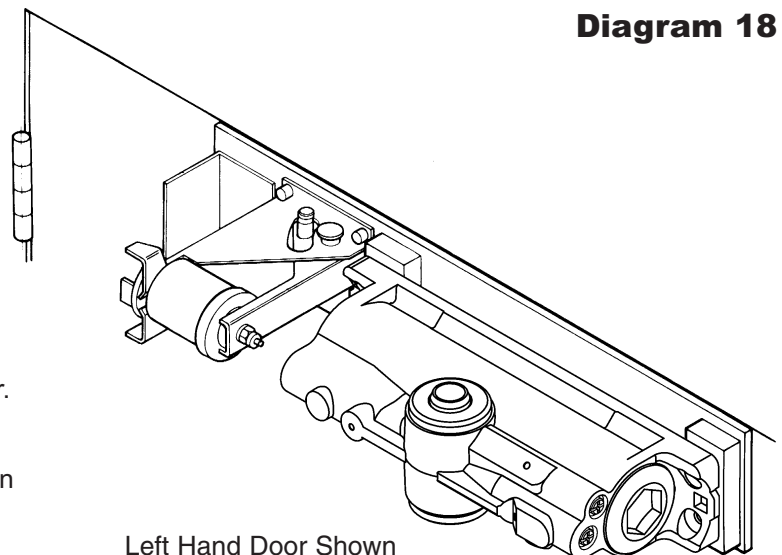
**Diagram 17**

### INSTALLATION INSTRUCTIONS



**Diagram 18**

- 1) Remove closer from backplate
- 2) Securely fix backplate **level** with underside edge of head-frame ensuring electro magnet is **nearest** hinge for either hand of door.  
**See Diagram 18**
- 3) Attach end of tension spring to lower peg ensuring end locates into groove.  
**See Diagram 18**
- 4) Securely fix arm bracket assembly to top rail of door.  
**See Diagram 18**
- 5) Re-fix closer securely to backplate ensuring hexagon recessed end of closer is **furthest** from hinges.  
**See Diagram 19**



**Diagram 19**

- 6) Connect wiring to electro magnet terminals and complete wiring installation through rear entry or side connecting conduit, refer to diagram 1 on main instruction sheet.

DETERMINE WHETHER UNIT IS TO HOLD DOOR OPEN OR ALLOW IT TO 'FREE-SWING' AND AT WHAT ANGLE FOR EITHER FUNCTION, THEN PROCEED AS FOLLOWS.

## SETTING ARM SET FOR HOLD OPEN

**85° to 95° RANGE OF HOLD OPEN** (only this range of hold catch open angle possible for Fig. 61).

- 1a) Couple main arm of arm set to catch plate by inserting bolt through centre slot.

**See Diagram 20**

- 1b) Insert arm set spindle into bottom of closer at 90° to backplate and secure with arm retaining screw.

**See Diagram 21**

- 2a) Pull main arm **towards** hinge until bolt is restricted and tighten nut. (THIS WILL GIVE MINIMUM HOLD OPEN POSITION).

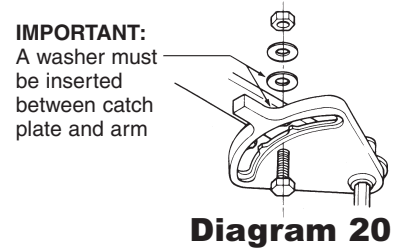
- 3a) Open door to engage secondary arm strip and tube. Close door and set secondary arm at 90° to door face. Securely tighten arm clamp bolt.

**See Diagram 22**

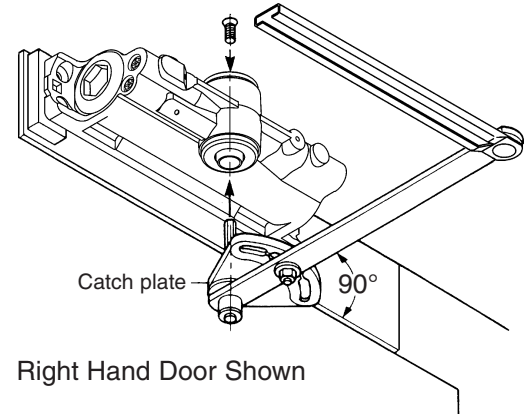
- 4a) Switch power on to energise unit magnet and open door until hold open is achieved.

- 5a) Slacken nut and move door to required hold open angle, then **securely** re-tighten nut.

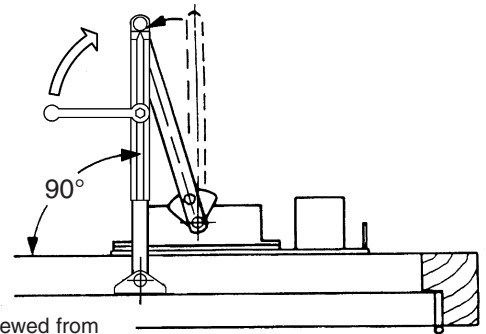
- 6a) Check that door will be released from this angle by de-energising the unit magnet.



**Diagram 20**



**Diagram 21**



**Diagram 22**

## SETTING ARM SET FOR FREE SWING (85° to 95° variance)

- 1c) Insert arm set spindle into bottom of closer at 90° as paragraph 1a and Diagram 20.

- 2c) Insert bolt into elongated slot **furthest** away from hinge. Place spacer over bolt and retain with nut Lock spacer down in the 85° position.

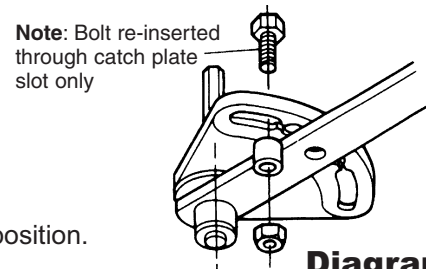
**See Diagrams 23 and 24**

- 3c) Assemble secondary arm and set length, connecting arm to arm bracket all as paragraph 3a).

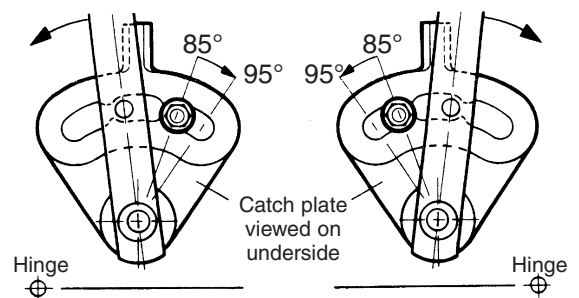
**See Diagram 22**

- 4c) Switch power on to energise unit magnet and open door until catch plate engages claw and door free swings. **To increase free swing angle** slacken nut, hold door at required free swing angle. **Ensure spacer is bearing against side of arm** before securely re-tightening nut

- 5c) De-energise unit magnet and check that claw releases catch plate causing door to close into its frame rebate.



**Diagram 23**



**Diagram 24**

## ADJUSTMENT TO CLOSER

**See Diagram 14 on main instruction sheet.**

Finally secure cover with two small screws.

**TESTING UNIT and MAINTENANCE:** Refer to main instruction sheet.

# INSTALLATION INSTRUCTIONS

0996/093/00

Issue 01

## BRITON 996 FIG.66

### ELECTRO MAGNETIC HOLD OPEN/FREE SWING DOOR CLOSER 24VDC

#### SURFACE FIXED TO 'PUSH' SIDE OF DOOR.

**SIZE 3** closer suitable for doors up to 950mm wide and 60kg in weight

**SIZE 4** closer suitable for doors up to 1100mm wide and 80kg in weight

**SIZE 5** closer suitable for doors up to 1250mm wide and 100kg in weight

This closer unit incorporates an electro magnet which is normally interfaced with a detector/alarm system. In an emergency or a power failure, the electro magnet when de-energised will cause the closer to close the door into its frame. A 13mm A/F spanner is required to carry out adjustments to arm set or convert from hold open to free swing function.

Hold open function enables unit to hold door open until automatically released or pulled closed manually. Angle of hold can be adjusted from 65° to 85° approx. and 90° to 105° approx.

Free Swing function setting allows door to be independent of closer control. When unit is automatically released the door will be driven closed from whatever position it may have been left open. Adjustment of catch plate provides for a free swing variance of 65° to 85° approx. Door can open to approx. 110° max. subject to hinge projection and surrounding structure.

**Warning:** When Briton 996 is used in the free swing mode the door is not under the control of the damping action and will slam in windy or draughty conditions.

THIS CLOSER UNIT IS EASILY CONVERTED TO SUIT EITHER HAND OF DOOR, for conversion instructions see diagram 4.

#### IMPORTANT

Door must swing freely and close firm into its rebate to enable the closer to operate efficiently. This is particularly important for fire/smoke doors and we recommend that doors be hung on ball bearing butt hinges to BS EN 1935 and that latches and smoke seals be of a type that offer minimum resistance to closing. Failure to address these requirements may result in an ineffective fire/smoke door installation.

DOOR STOP MUST BE FITTED TO PREVENT DOOR FROM OPENING JUST BEYOND SET ANGLE OF HOLD OPEN OR FREE SWING SETTING.

Under no circumstances should the door closer be dismantled.

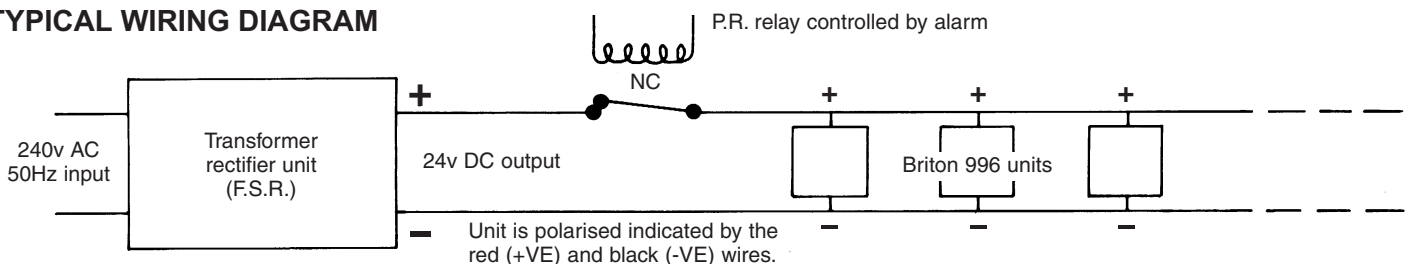
## ELECTRICAL INFORMATION

**SPECIFICATION** Electro-magnet continuous rating: 2.35 watts max at 26v DC.  
Power Requirements: 24v DC - 90 mA nominal.

**TESTING** Check that voltage is within specified range at each unit after installation.  
It is recommended that the equipment is tested at weekly intervals for correct function.

**NOTE: Power for ancillary devices must not be drawn from the alarm system except under alarm conditions and then must not reduce the reliability of the supply. (BS.5839 Pt. 1).**

#### TYPICAL WIRING DIAGRAM



**NOTE:** Power supply feed to electro magnet is through flexible armoured loop.

**Diagram 1**

#### IMPORTANT

This closer should be installed by a competent fixer who must pass these instructions onto the site or maintenance manager once the closer unit has been satisfactorily fixed, wired and tested.

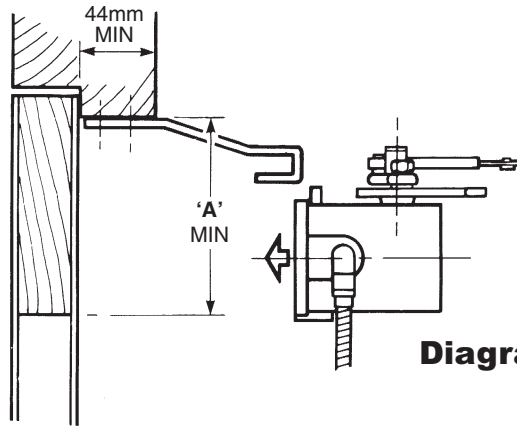
**No Responsibility** can be accepted by the manufacturers if these installation instructions are disregarded.

## APPLICATION

Briton 996 unit fixed to top rail of door. Arm bracket fixed to head frame.

**See Diagram 2**

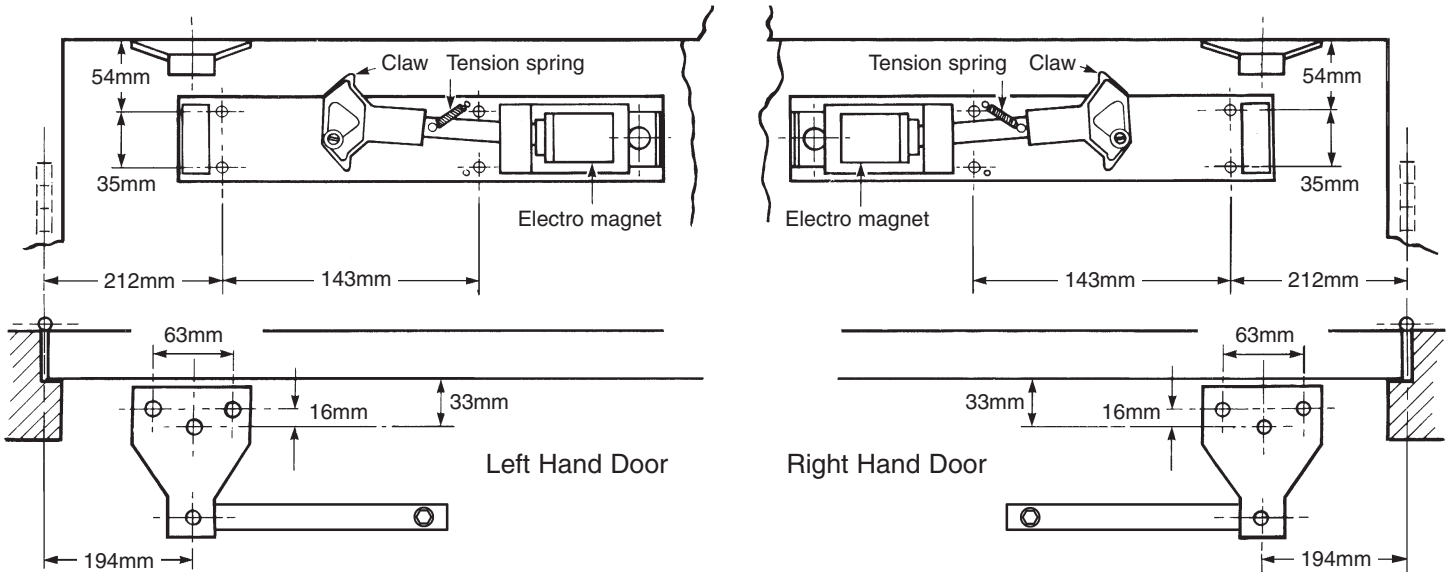
**\*Note:** Adjacent chart indicates where drop plates are required. Drop plates are supplied on request.



Minimum Depth 'A' required to fix unit	
without drop plate	with drop plate
100mm	41mm

**Diagram 2**

## INSTALLATION INSTRUCTIONS



**Diagram 3**

- 1) Remove closer from backplate.
- 2) With electro-magnet **furthest** from hinges, **securely** fix backplate to door, **parallel** with underside of head.

**See Diagram 3**

**Note:** When drop plate is used, screw it to top rail **first** ensuring tapped holes in plate line up with dimensions **shown in diagram 3**.

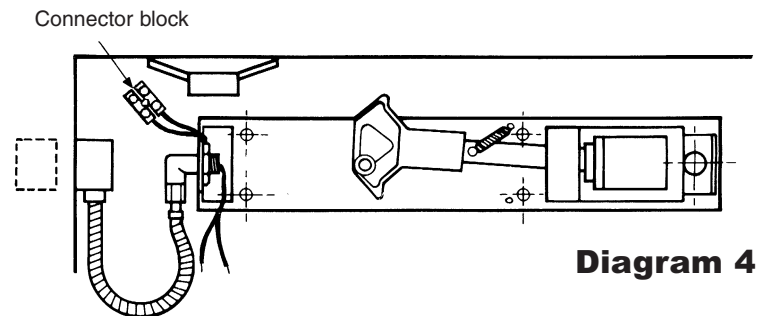
- 3) Attach free end of tension spring to upper peg ensuring end locates into groove. Depress claw and check for free return.
- 4) Open door and securely fix arm bracket assembly to underside of head frame.
- 5) Fix junction box complete with armoured cable to side or face of jamb in line with backplate.

**See Diagram 4**

- 6) Attach elbow end of cable to angle bracket using elbow nut. Temporarily bend wiring back.

**See Diagram 4**

- 7) DETERMINE WHETHER UNIT IS TO HOLD DOOR OPEN OR ALLOW IT TO 'FREE SWING' AND AT WHAT ANGLE FOR EITHER FUNCTION



**Diagram 4**

# SETTING ARM SET FOR HOLD OPEN

## 65° to 85° RANGE OF HOLD OPEN

- 1a) Couple main arm of arm set to catch plate by inserting bolt through **first slot** for hand of door required.

**See Diagrams 5 and 6**

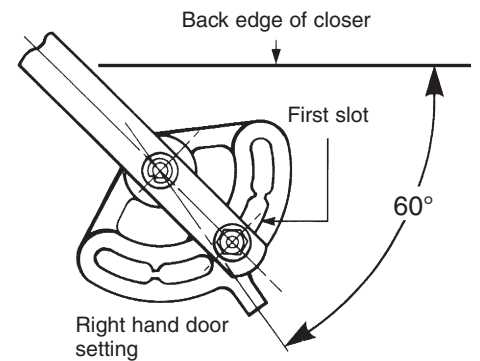
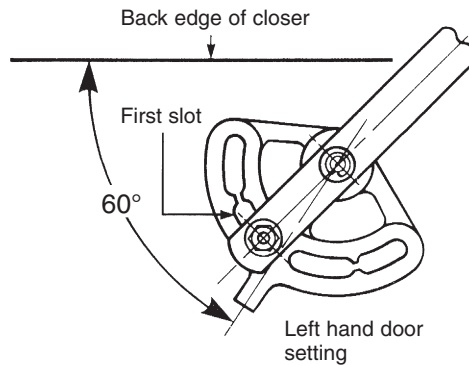
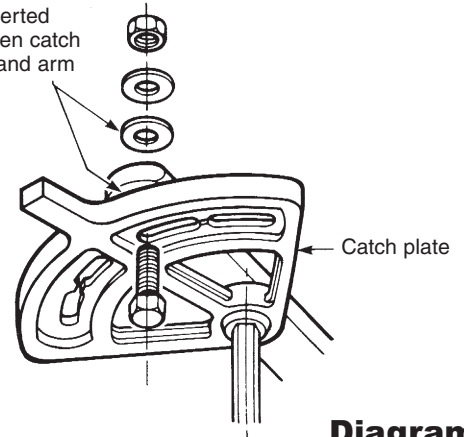
Pivot arm until bolt is at end of slot **nearest** central lug on catch plate.

**Firmly** tighten down nut in this position.

**See Diagram 6**

THIS WILL GIVE MINIMUM ANGLE OF HOLD OPEN WITHIN THE DESIRED RANGE.

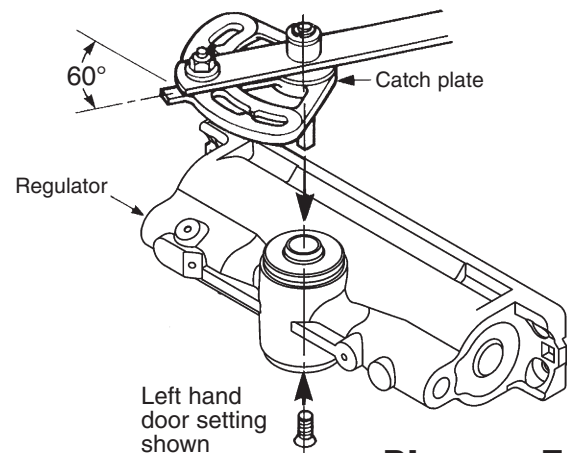
IMPORTANT:  
A washer must be inserted between catch plate and arm



**Diagram 6**

- 2a) Insert arm set spindle into top of closer with catch plate lug **towards** regulator end of closer **and 60° to back edge of closer**. Secure spindle with retaining screw.

**See Diagrams 6 and 7**



**Diagram 7**

OR

## 90° to 105° RANGE OF HOLD OPEN

- 1b) Couple main arm of armset to catch plate by inserting bolt through **second slot** for hand of door required.

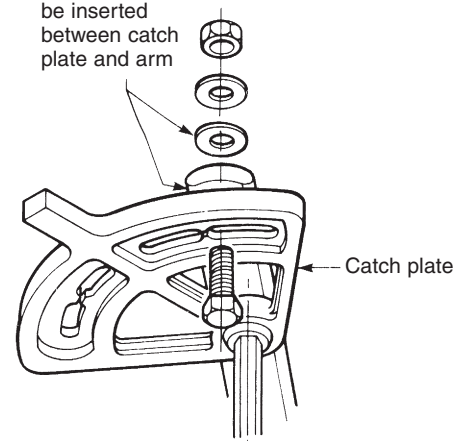
**See Diagrams 8 and 9**

Pivot arm until bolt is at end of slot **nearest** central lug on catch plate. Firmly tighten down nut in this position.

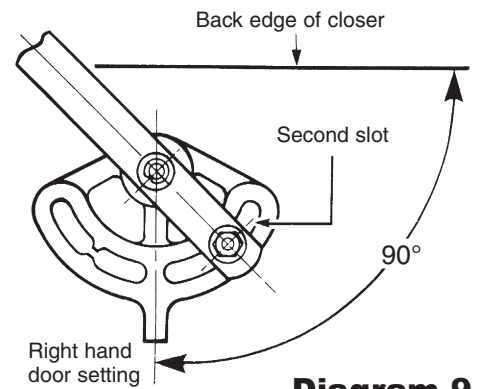
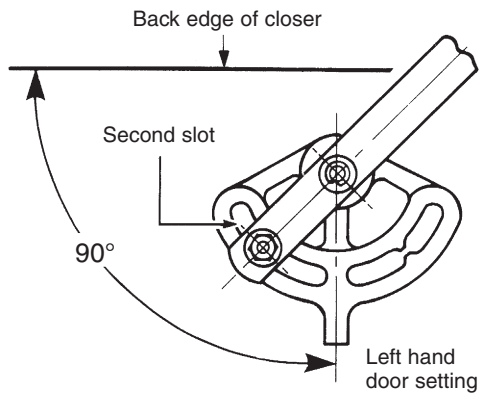
**See Diagram 9**

THIS WILL GIVE MINIMUM ANGLE OF HOLD OPEN WITHIN THE DESIRED RANGE.

IMPORTANT:  
A washer must be inserted between catch plate and arm

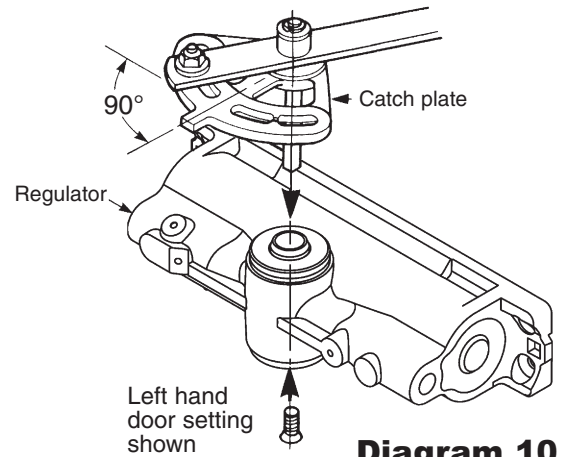


**Diagram 8**



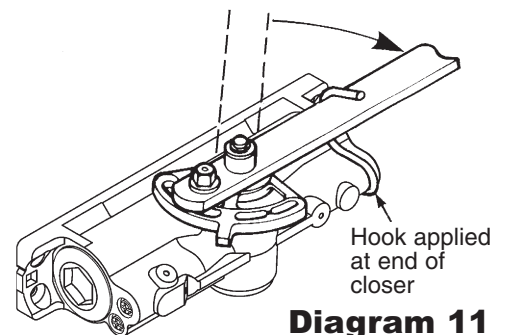
**Diagram 9**

- 2b) Insert arm set spindle into top of closer with main arm pointing towards regulator end of closer and catch plate lug at **90° to back edge of closer**. Secure spindle with retaining screw.  
**See Diagrams 9 and 10**



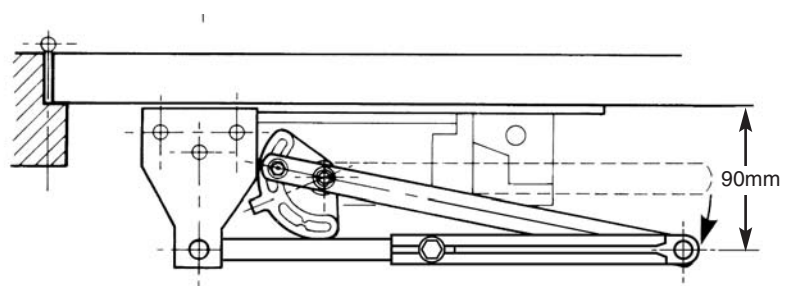
**Diagram 10**

- 3) Pull main arm forward over closer body and hold in this position using hook provided.  
**See Diagram 11**
- 4) Secure closer body firmly to back plate pads with 4—M5 screws ensuring regulator end of closer is **furthest** from the electro magnet. Connect wiring from cable loop to wiring from electro magnet.
- 5) Open door to engage secondary arm strip and tube then close door. Pull main arm until hook is released and secondary arm is 90mm from door face. Securely tighten arm clamp bolt. Check to ensure the 90mm is maintained after tightening.  
**See Diagram 12**



**Diagram 11**

- 6) Complete wiring installation as shown in **Diagram 1**
- 7) Switch power on to energise unit magnet and open door until hold open is achieved.
- 8) If hold open angle needs to be increased, slacken nut and move door to required hold open position then **securely** retighten nut.
- 9) Check that door will be released from hold open angle when magnet is de-energised.



Left hand door shown

**Diagram 12**

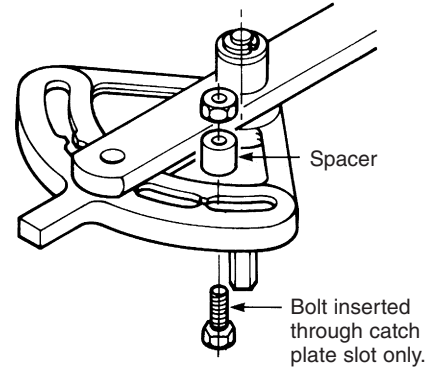
# SETTING ARM SET FOR FREE SWING

(65° to 85° VARIANCE)

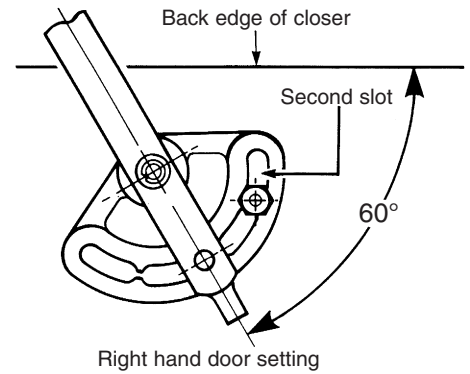
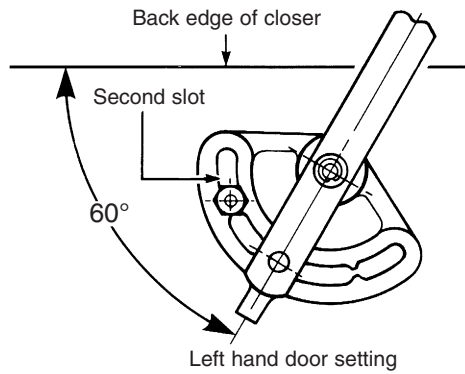
- 1c) Insert bolt into second elongated slot in catch plate with bolt **nearest** central lug. Place spacer over bolt and retain by firmly tightening down nut.

**See Diagrams 13 and 14**

THIS WILL GIVE MINIMUM ANGLE OF FREE SWING WITHIN THE STATED RANGE.



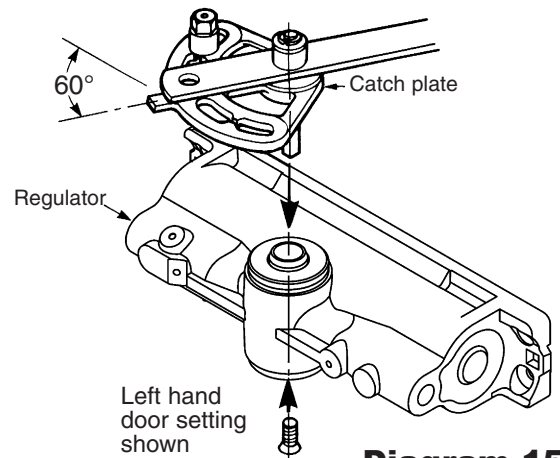
**Diagram 13**



**Diagram 14**

- 2c) Insert arm set spindle into top of closer with catch plate lug **towards** regulator and **60° to back edge of closer**. Secure spindle with retaining screw.

**See Diagrams 14 and 15**

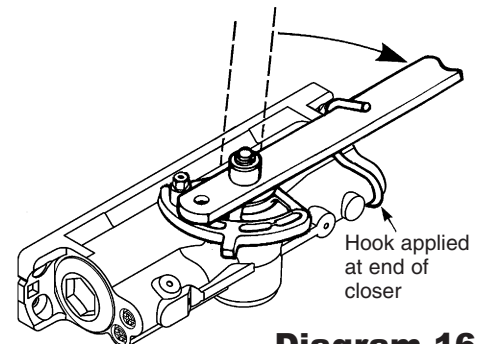


**Diagram 15**

- 3c) Pull main arm forward over closer body and hold in this position using hook provided.

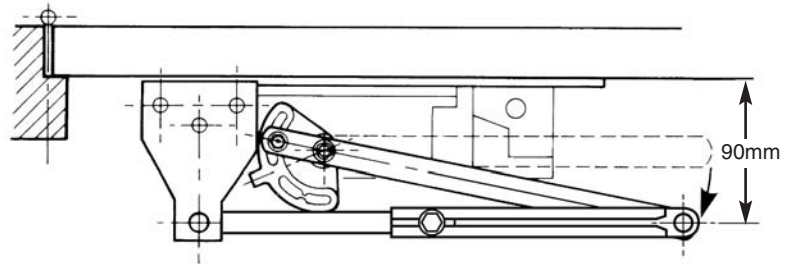
**See Diagram 16**

- 4c) Secure closer body firmly to backplate pads with 4-M5 screws ensuring regulator end of closer is **furthest** from electro magnet. Connect wiring from cable loop to wiring from electro magnet.



**Diagram 16**

- 5c) Open door to engage secondary arm strip and tube then close door. Pull main arm until hook is released and secondary arm is 90mm from door face. Securely tighten arm clamp bolt. Check to ensure the 90mm is maintained after tightening.  
**See Diagram 17**



**Diagram 17**

- 6c) Complete wiring installation as shown in **Diagram 1**

- 7c) Switch power on to energise unit magnet and open door until catch plate lug engages sprung claw and door 'free swings'.

- 8c) If free swing angle need to be increased, slacken nut, hold door at required free swing angle and retighten nut. (Ensure arm is bearing against spacer **before** securely re-tightening nut.

- 9c) De-energise unit magnet and check that claw releases catch plate causing door to be driven to the closed position by the closer.

## ADJUSTMENT TO CLOSER

### Closing speed and Latch Action Adjustment.

Turn regulator for suitable closing speed  
**+ faster** or **- slower**.

Turn regulator for suitable latch speed  
**+ faster** or **- slower**.

### See Diagram 18

**WARNING:** REGULATORS MUST NOT BE UNSCREWED BEYOND SURFACE OF BODY

### TESTING UNIT

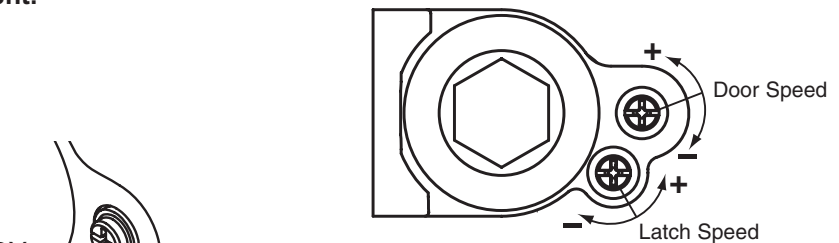
Switch on power supply to apply 24vDC to unit. Open door until either hold open or free swing function has been achieved. Switch off power to de-energise unit and observe that closer returns door, under check control, firmly into frame.

Hold cut out trim in position behind lower spindle boss of closer butting up against back plate of door. Slide cover over unit ensuring trim is retained. Finally secure cover with two small screws.

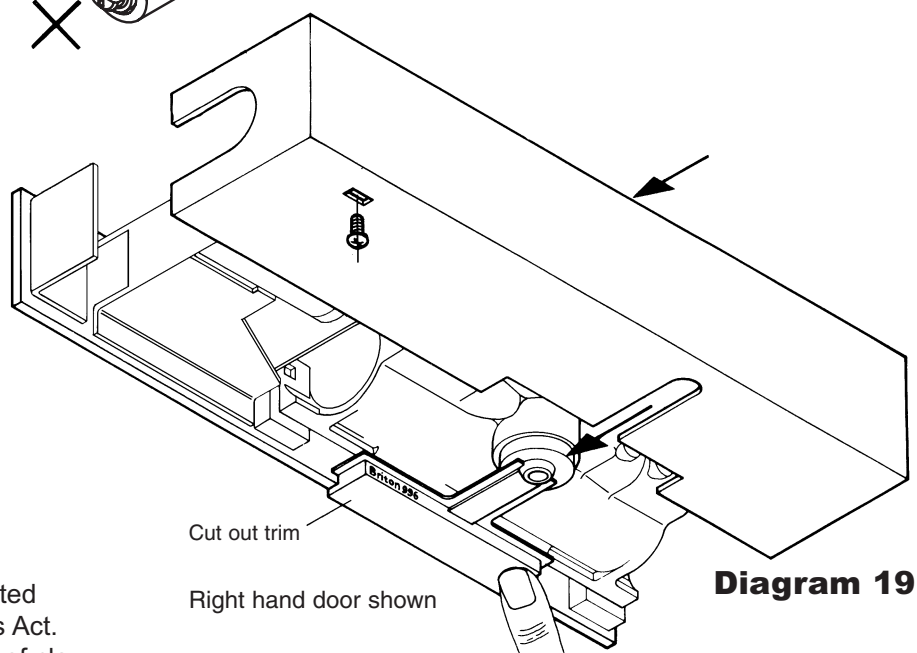
### See Diagram 19

### MAINTENANCE

Keep free from dust and dirt. Unit to be tested weekly in accordance with Fire Precautions Act. Periodically apply grease to projecting part of claw and a small quantity of oil to arm joints and door hinges.



**Diagram 18**



**Diagram 19**